

# Performance Plus Swing-Flo M/E OPTIONS & INSTALLATIONS

**RAPAT**  
CORPORATION

## ACCESSORIES

Durability and common-sense engineering make our accessories the finest available!

We offer solid construction and a wide choice of sizes and options available to compliment your new or existing system.

Custom accessories are also available to suit industry-specific uses. For more information on accessories please consult your Gerber representative.



## ELECTRIC SWING-FLO

All Swing-Flo models are available as electrically-controlled units with a control panel for remote control operation from your office, driveway or other convenient location(s). Multiple control panels are also available, so that the Swing-Flo system may be controlled at different locations throughout your operation.

The control panel system includes a intrinsically safe proximity sensor with barrier relay and brake motor to position the inner spout; and a remote control panel, digital position readout with mal-functions displayed.

## ELECTRIC SWING-FLO FEATURES

Proximity switch position target at each duct location provides positive alignment with spout.

Most electrical components are mounted outside unit for dust-free operation.

Minimal wiring to connect distributor to control panel. Motor wires to be determined by electrician and run in a separate conduit.

Can be designed to interface with other automated control systems.

## MANY SPOUT OPTIONS AVAILABLE

Gerber can supply spouts, elbows, driveway clam gate load-out chutes and any other items needed to complete your installation.



**RAPAT**  
CORPORATION

The Rapat Corporation • 919 O'Donnell Street • Hawley, MN 56549

TF: 800-325-6377 • T: 218-483-3344 • F: 218-483-3535 • E: info@rapat.com • www.rapat.com

RAPAT SPECIALIZES  
IN THE CUSTOM DESIGN  
OF BELT CONVEYORS  
FOR ALL INDUSTRIES.

# Performance Plus Swing-Flo M/E OPTIONS & INSTALLATIONS

## UNIQUE FAN SHAPE DESIGN REDUCES WEAR

The Performance-Plus Swing-Flo has been designed to withstand heavy-duty operational needs with minimal wear and maintenance requirements.

The Swing-Flo's inner spout design evenly distributes wear for a significantly increased working life.

## ADAPTABILITY AND SHAPE CUT INSTALLATION COSTS

The Swing-Flo is adaptable to low vertical height and can be mounted virtually flat against a wall in a cramped area.

Alternating offset outlets and straight end outlets with fewer bends for better material handling.

Our double inlet unit for handling two legs means easier installation— requiring little more space than a single unit.

The manual version of the Swing-Flo is easily upgraded to the electric version at a later date.

Inner parts are easily accessible through large doors located at each end of the Swing-Flo.

## SWING FLO SPECIFICATIONS

<b>Size</b>	Any size is available. Swing Flo Distributors are custom made to fit your needs.
<b>Controls</b>	Manual or Electric controls are available for all installations.
<b>Ducts</b>	8" to 18" Ducts are available.
<b>Intakes</b>	Single or double intake.
<b>Discharge</b>	3 to 18 Discharge Ducts available per Swing Flo Distributor.
<b>Standard Construction</b>	Carbon steel body with carbon steel inner parts. Carbon steel outlet ducts.
<b>Heavy Duty Construction</b>	Carbon steel body with abrasion resistant steel inner parts. Carbon steel outlet ducts. Steel gauges may vary, depending on total size or unit required.

All specifications subject to change without notice.

## ELECTRIC SWING-FLO

### ACCESS DOORS

Access doors are located on both sides of Swing-Flo for easy repair and replacement of internal parts.

### STEEL MOUNTS

Allow easy installation of Swing-Flo.

### SPOUTS

Formed and welded steel outlet spouting. Many choices of connectors, flanges and lining material available.

### INSPECTION DOORS

Designed for easy repair, adjustment and replacement of internal parts.

### ELECTRIC CONVERSION

Manual unit is easily retrofitted on-site with electric control package.

### BEARINGS

Located on outside of Swing-Flo for dust-free operation and convenient maintenance.

### EXTERNAL OUTLET DUCT FLANGES

Designed for more rigid construction and easy repair.

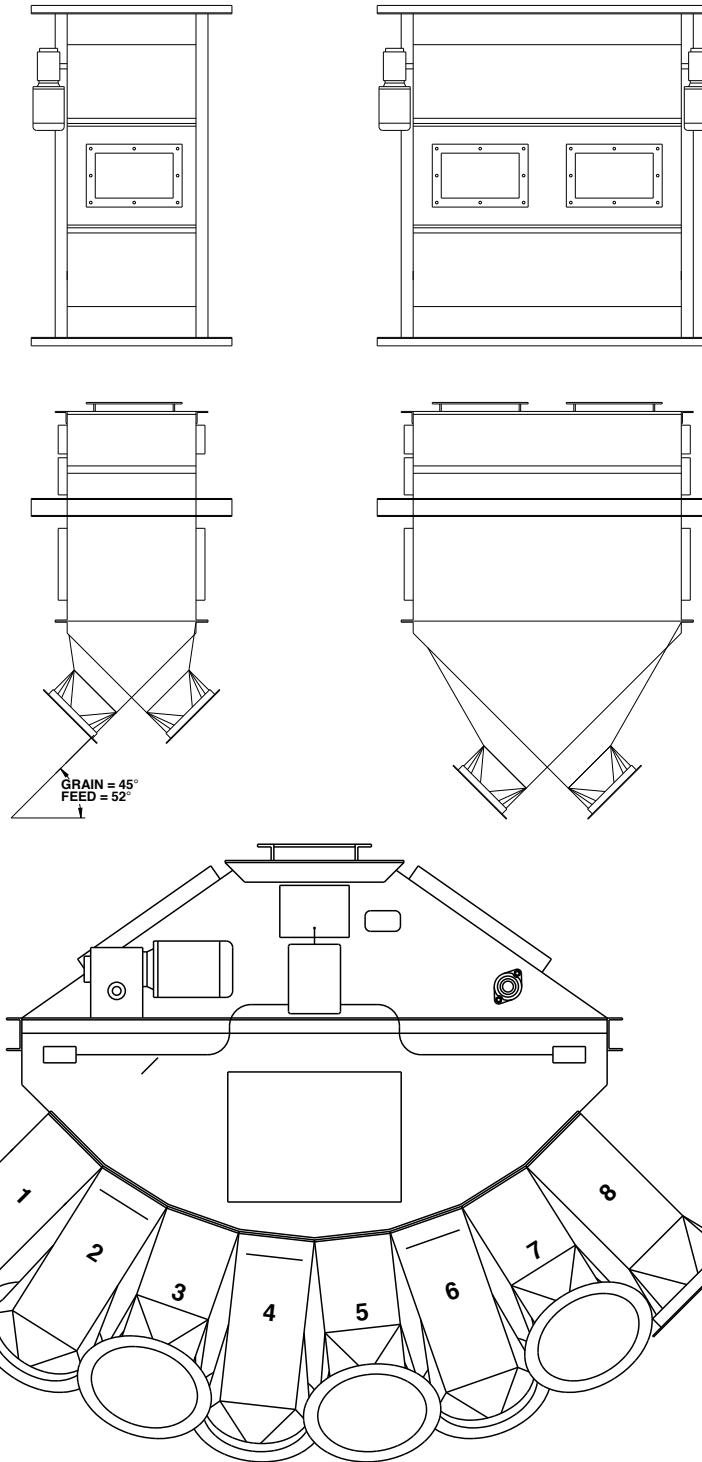

## EASY MAINTENANCE BUILT-IN

Swing-Flo parts can be easily removed through the unit's end door for fast, efficient replacement of parts.

The Swing-Flo is weather-tight for outdoor installations, and our Electric Drive option interfaces easily with automated computer-controlled systems.

## SWING FLO OPTIONS

- **ELECTRIC DRIVE -**  
Allows easy spout outlet location changes.
- **OPTIONAL MATERIALS -**  
Galvanized and stainless steel units available.
- **OPTIONAL LINERS -**  
Optional liners include Urethane, UHMW, Abrasion Resistant Steel.
- **CONSTRUCTION OPTIONS -**  
Larger units may be knocked down or designed to be split for easier, more cost-effective shipping.

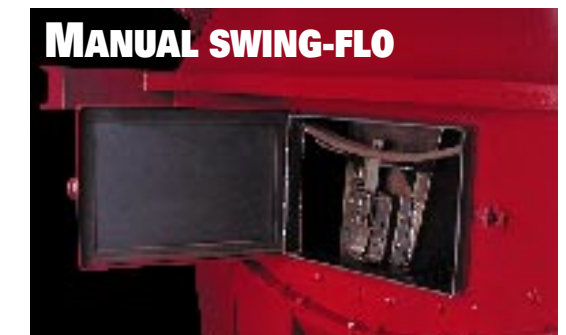
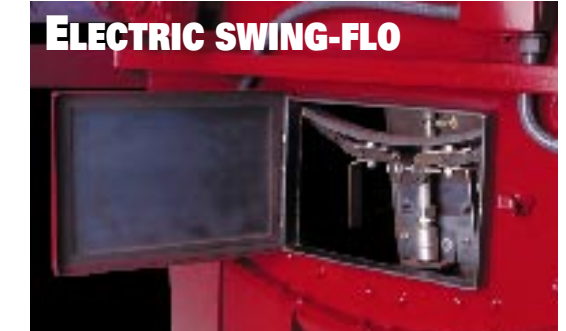

**RAPAT**  
CORPORATION