

Series F Conveyor OPTIONAL FEATURES

RAPAT

C O R P O R A T I O N



HEAVY DUTY BULK HANDLING

For applications that require high capacities or heavy duty conveying, Rapat offers a full line of dual or three roll idler conveyors with formed or structural channel frames.



RUBBER LINED HOPPER

Fragile products such as seed or edible beans are loaded into the conveyor gently, reducing product damage.

TRUSS SUPPORT SYSTEM

Designed specifically for conveyors over 70' in length. The Truss Support System provides the added support necessary for a strong frame assembly.

SERIES CU CONVEYOR

The Rapat Series CU Conveyor is an excellent companion to the Series F Conveyor for unloading hopper bottom trailers and railcars.



PIVOT WHEEL ASSEMBLY

The Pivot Wheel Assembly is also designed for side-to-side movement between bins and buildings.

SERIES F CONVEYOR

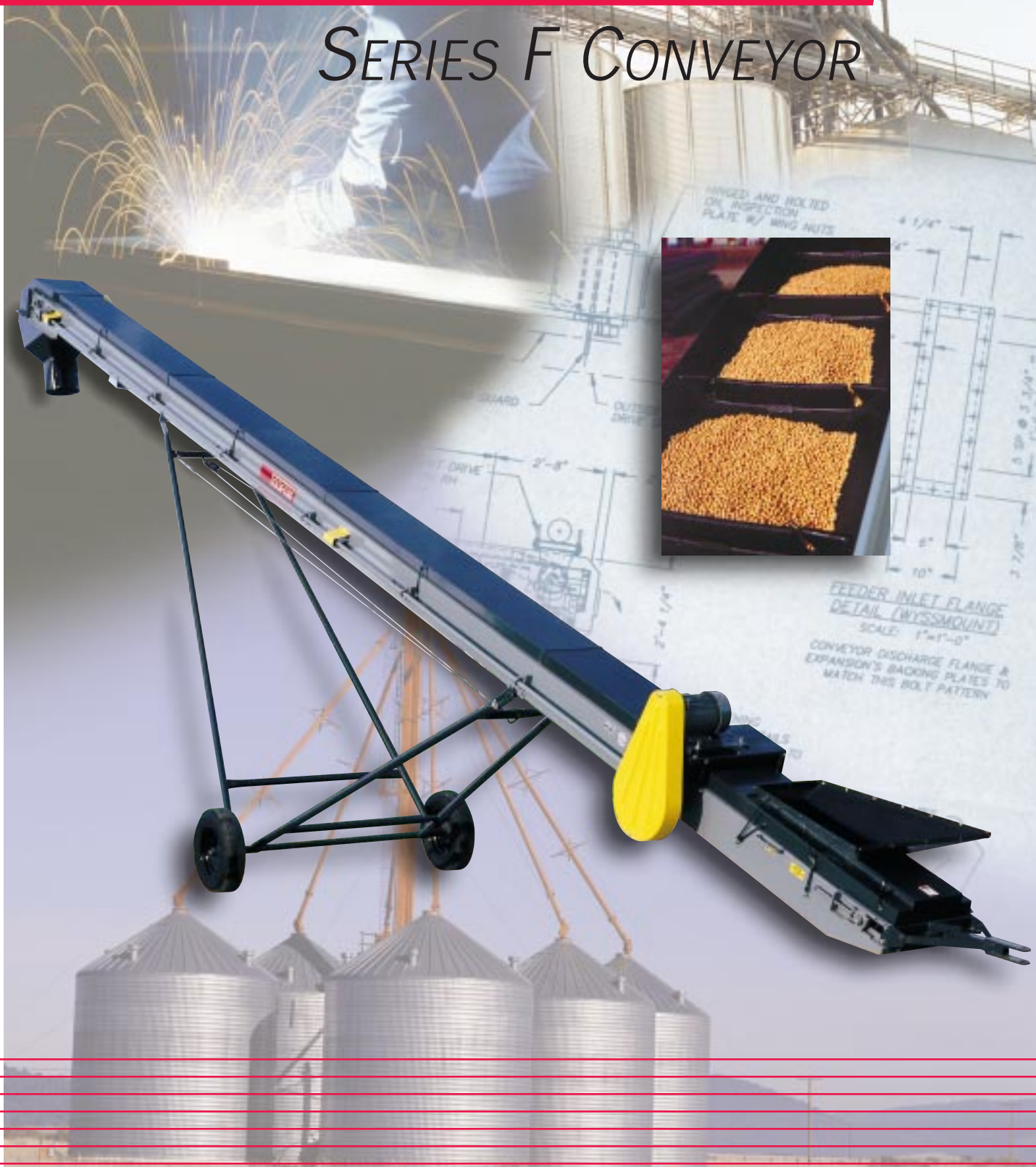

RAPAT CORPORATION PRODUCT LINE CARD

CONVEYORS

- ENCLOSED BELT
- BAGGING
- CLEATED BELT
- TRUCK & RAILCAR UNLOADERS
- FLEXIBLE SIDEWALL
- PORTABLE BELT
- FOOD HANDLING
- TROUGHING ROLLER
- PLASTIC & WIRE BELTS
- SLIDER BED
- STAINLESS STEEL CONSTRUCTION
- EN-MASSE (DRAG)
- CUSTOM CONVEYORS

DISTRIBUTORS

- ROTO-FLO
- ROTARY VALVE
- SWING-FLO

BUCKET ELEVATORS

- COMPLETE BUCKET ELEVATOR ASSEMBLIES
- CUSTOM ACCESSORIES
- BACKLEG ROLL OPTIONS

SCREW CONVEYORS

- TUBE TYPE SCREW CONVEYORS
- AUGER FLIGHTING

HORIZONTAL UNLOAD POWERHEADS

- 25 DEGREE INCLINE POWERHEADS
- BIN UNLOAD TUBES WITH ROLLER SLIDE GATES
- BANJO SUMP BIN UNLOAD TUBES
- ELECTRIC / HYDRAULIC DRIVE KITS

ACCESSORIES

- HOPPER CAR UNLOADERS
- TRANSFER SPOUTING
- CAST IRON TURNHEADS
- REVERSIBLE ELBOWS
- DRAW OFF SPOUTS

INDUSTRIAL MATERIAL HANDLING SOLUTIONS THAT WORK!

At The Rapat Corporation, we approach each project with the intent of finding a better way to solve our customers' problems by listening to their individual needs, and applying what we learn to best solve their specific material handling requirements.

Put our experience with some of the largest Fortune 500 Corporations to work for you—call toll-free today for more information.

RAPAT

C O R P O R A T I O N

The Rapat Corporation ■ Hawley Industrial Park ■ Hawley, MN 56549 USA
Toll Free (800) 325-6377 ■ (218) 483-3344 ■ Fax (218) 483-3535 ■ www.rapat.com

Series F Conveyor FEATURES

SERIES F CONVEYORS

The Rapat Series F Conveyor is a rubber belt conveyor designed for gentle handling of bulk materials such as seed, beans, fertilizer, earcorn, etc.

The conveyor can elevate up to a 40 degree incline. The rubber flights are hot vulcanized to the rubber belt and convey the materials without cracking or grinding.

The Rapat Series F Conveyor is versatile! Installation options range from wheel undercarriages to permanent leg assemblies, to pivot wheel assemblies for specialized uses. It is easy to move and clean. Formed steel covers provide sun and wind protection for your products.

The 18" wide belt will handle approximately 2,500 BPH. The 24" wide belt will handle approximately 3,500 BPH. Capacities are based on a 30 degree angle and may vary. Please consult your Rapat representative to determine the best solution for your needs.

SERIES F SPECIFICATIONS

Lengths	20' to 70' in 10' increments.
Belt	18" or 24" wide with 2" high molded cleats on 12" centers.
Drive	Positive gearbox and shaft drive with roller chain final drive.
Frame	Formed and welded steel frame with self-cleaning bed and inclined sides to form trough.
Power	Conveyor can be driven by electric or hydraulic motor, gas engine or PTO.
Undercarriage	Heavy-duty undercarriage complete with manual winch, removable towing hitch, and rims and tires.
Pulleys	8" diameter machined head pulley with vulcanized lagging and drum type tail pulley.
Covers	Removable steel covers with inlet hopper and discharge spout standard.

All specifications subject to change without notice.

SERIES F OPTIONS

LENGTHS -

Custom lengths for permanent installation. Also, longer conveyors are available with truss kits for portable applications.

BELT -

6" and 9" cleat spacings are available for greater capacities at steeper incline angles.

110V ELECTRIC WINCH -

Two-button hand switch with a 10 foot cord allows the operator to keep an eye on the conveyor while making adjustments to the discharge height. (See photo at right).

PIVOT WHEEL ASSEMBLY -

Bolt-on tandem arms with four wheels. Permits you to adjust wheels for side-to-side movement. (See back page for photo and more information).

RUBBER LINED HOPPER/SPOUT -

For more gentle handling of fragile products such as seed or edible beans. (See back page for photo and more information).

SELF-CLEANING TAIL PULLEY -

Reduces material clogging and potential damage.

HIGH CLEARANCE PACKAGE -

Used for bulky or large product such as earcorn, range cubes or recyclables. Package consists of open-throat hopper, 10" high sides with cover and large discharge hood.

OPTIONAL 304 STAINLESS STEEL CONSTRUCTION -

For corrosive applications.

HYDRAULIC WINCH -

Allows easy raising and lowering of your conveyor. Comes with 1/2" N.P.T.F. hydraulic connections, no fittings provided.

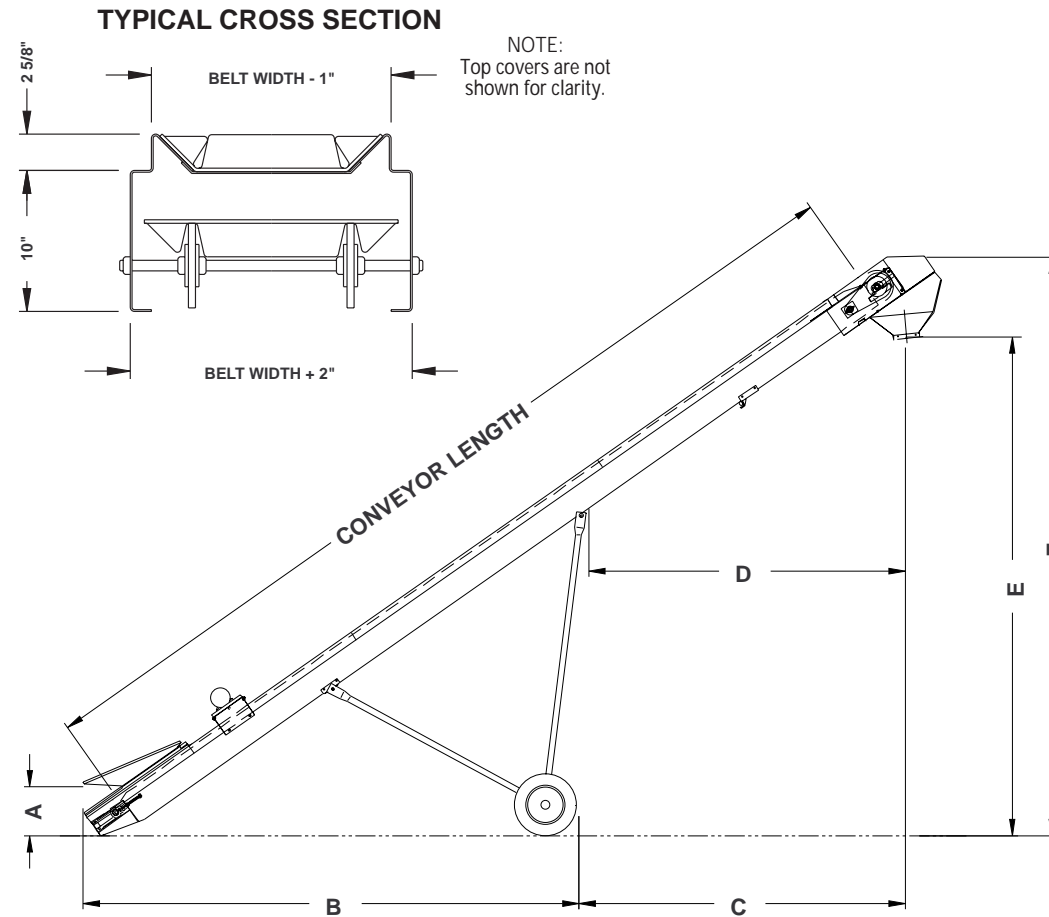

SERIES F CONVEYOR DIMENSIONS

		20'	30'	40'	50'	60'	70'
25°	A	1' - 10"	1' - 10"	1' - 10"	1' - 10"	1' - 10"	1' - 10"
	B	12' - 2"	17' - 4"	21' - 9"	27' - 4"	32' - 1"	35' - 5"
	C	7' - 11"	11' - 9"	16' - 5"	19' - 11"	24' - 2"	29' - 11"
	D	4' - 6"	7' - 8"	9' - 8"	9' - 3"	13' - 0"	18' - 4"
	E	7' - 5"	11' - 8"	15' - 10"	20' - 1"	24' - 4"	28' - 7"
	F	10' - 1"	14' - 4"	18' - 6"	22' - 9"	27' - 0"	31' - 2"
30°	A	1' - 10"	1' - 10"	1' - 10"	1' - 10"	1' - 10"	1' - 10"
	B	11' - 11"	16' - 10"	21' - 0"	26' - 5"	30' - 10"	34' - 6"
	C	7' - 5"	11' - 3"	15' - 8"	18' - 11"	23' - 2"	28' - 2"
	D	5' - 4"	9' - 0"	11' - 3"	11' - 3"	15' - 6"	20' - 10"
	E	9' - 2"	14' - 2"	19' - 2"	24' - 2"	29' - 2"	34' - 2"
	F	11' - 9"	16' - 9"	21' - 9"	26' - 9"	31' - 9"	36' - 9"
35°	A	1' - 9"	1' - 9"	1' - 9"	1' - 9"	1' - 9"	1' - 9"
	B	11' - 8"	16' - 2"	20' - 1"	25' - 4"	29' - 4"	33' - 5"
	C	8' - 5"	10' - 7"	14' - 10"	17' - 9"	21' - 11"	26' - 1"
	D	6' - 1"	10' - 3"	12' - 9"	13' - 2"	17' - 9"	23' - 1"
	E	10' - 9"	16' - 6"	22' - 2"	27' - 11"	33' - 8"	39' - 5"
	F	13' - 5"	19' - 2"	24' - 11"	30' - 8"	36' - 5"	42' - 1"
40°	A	1' - 8"	1' - 8"	1' - 8"	1' - 8"	1' - 8"	1' - 8"
	B	11' - 4"	15' - 4"	19' - 1"	24' - 1"	27' - 8"	32' - 2"
	C	6' - 3"	9' - 11"	13' - 11"	16' - 6"	20' - 7"	23' - 9"
	D	6' - 9"	11' - 3"	13' - 11"	14' - 8"	19' - 5"	24' - 11"
	E	12' - 3"	18' - 8"	25' - 1"	31' - 6"	37' - 11"	44' - 5"
	F	15' - 0"	21' - 6"	27' - 11"	34' - 4"	40' - 9"	47' - 2"

Dimensions in the chart above have a tolerance of plus or minus 1 inch.

ELECTRIC MOTOR -

Conveyor may be powered by three phase or single phase electric motors.

PTO DRIVE -

A six-spline, 540 RPM PTO shaft drive system.

GASOLINE ENGINE -

Package includes motor mount with leveling screw, battery and clutch. Electric start available on most models. Permits easy operation without a tractor or other power source.

HYDRAULIC DRIVE -

Orbit motor provided at discharge end of conveyor. User supplies lines from power source to connectors at lower end of conveyor.



SPLIT RETURN ROLLERS
Assure proper belt tracking and reduced wear for flighted belt.

GENTLE FLOW DISCHARGE HOOD



Allows gentle transition of fragile products such as seed or edible beans.

RAPAT
CORPORATION