

Series V/HDV Belt Conveyor OPTIONS & INSTALLATIONS

Series V/HDV Belt CONVEYORS



BAG TURNER

The Bag Turner option is placed between two conveyors. The bags move along the first conveyor, and are tipped on their side, and rotated by the shorter conveyor on the Bag Turner. The bags are then properly positioned to move onto additional conveyor systems.

OPTIONAL MANUAL JACK ASSEMBLY

Height adjustment is easy with the Manual Jack Assembly option. Dual screw jacks with a common connecting shaft assures level conveying at any height. Provides 12" of adjustment.



FOOT OPERATED SWITCH

Allows operator to control conveyor start/stop while having hands free for other bagging operations.



CUSTOM CONVEYORS

Shown on the left is a custom bagging conveyor utilizing structural channel frame, stainless steel bed rollers and a plastic belt.

The Rapat Corporation specializes in the custom design of conveying systems for bulk and packaged materials.

Rapat can design an economical system for moving your material gently and efficiently.

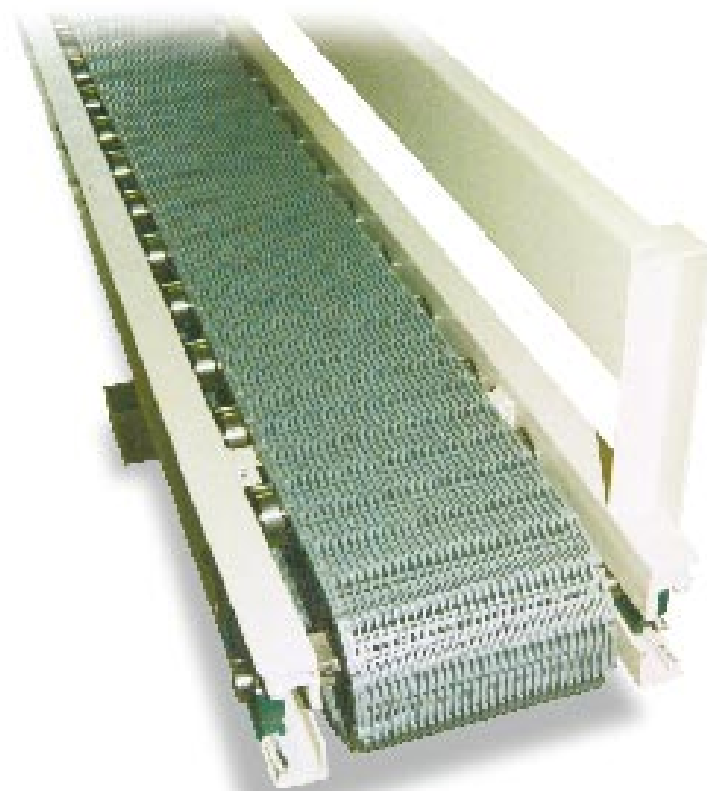

SERIES V CONVEYOR
(Shown with optional 2"x4" Tubing Support Stands)

SERIES HDV CONVEYOR
(Shown with optional Manual Jack Assembly)



THE RAPAT CORPORATION
HAWLEY INDUSTRIAL PARK • HAWLEY, MINNESOTA 56549
(800) 325-6377 (218) 483-3344 FAX (218) 483-3535

RAPAT SPECIALIZES
IN THE CUSTOM DESIGN
OF BELT CONVEYORS
FOR ALL INDUSTRIES.



Series V/HDV Belt Conveyor FEATURES

MAKE YOUR BAG HANDLING OPERATIONS RUN SMOOTHLY

Whether you operate a one-person shop or a multi-line facility, Rapat's full line of bagging conveyors are here to assist you in running an efficient operation.

Rapat's Series V Conveyors may be used alone or in custom configurations to convey packaged product throughout your facility.

DEPENDABLE CONVEYORS FOR ANY TASK

The Rapat Series V Conveyor line includes two reliable conveyors; the Series V and HDV.

Each conveyor may be used in conjunction with sewing machines and heat sealers. The "V" design keeps bags in an upright position without bag guides.

OPTIONS MAKE CUSTOM CONFIGURATIONS EASY

We offer many options to allow the V/HDV conveyor to fit your individual use.

Contact our system designers today to get the latest information on options that may be added to the standard V/HDV models to give you the system you need.



SERIES HDV MOTOR MOUNT DETAIL

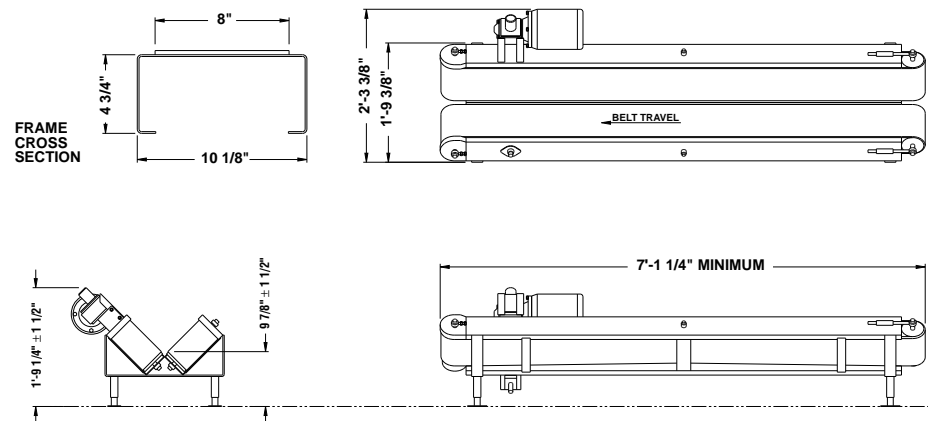

SERIES V CONVEYOR

The Rapat Series V Belt Conveyor is an economical slider bed conveyor for light to medium duty bagging operations.

Reduce labor costs and increase productivity without the expense of an elaborate conveying system.

This conveyor may be used in conjunction with portable sewing equipment or with a stationary sewing pedestal.

SERIES V SPECIFICATIONS

Lengths (Outside of pulleys)	Standard length is 7'. Optional lengths available to 14'.
Belt	Two 8" wide, 120# smooth PVC belts with mechanical belt fasteners. Belt speed is 35 FPM.
Drive	Right angle gear reducer with roller chain final drive.
Frame	12 gauge formed and welded steel slider bed.
Power	1/2 hp TEFC single phase C face motor for 7' through 10' lengths, 1 hp for 11' through 14' lengths.
Pulleys	4" diameter head and tail pulleys.
Supports	Pipe leveling legs for 8 1/2" to 11 1/2" top-of-belt heights.

All specifications subject to change without notice.

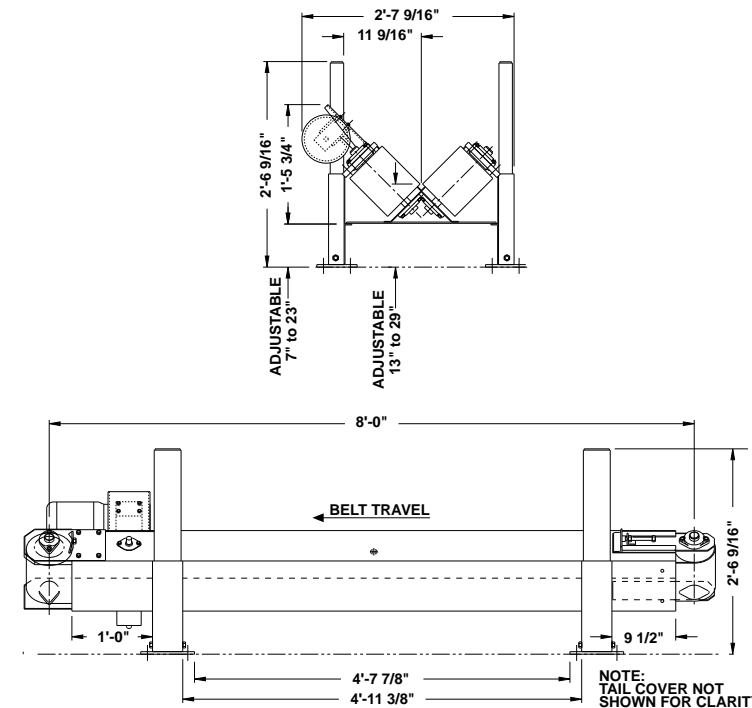

SERIES HDV CONVEYOR

The Rapat Series HDV Belt Conveyor is built for your rugged bagging applications.

From the dual belt conveying surface to the heavy-duty shafts and bearings, this conveyor is designed for long, hard hours of dependable service.

By incorporating the adjustable dual screw jack assembly, top-of-belt heights may be adapted to accommodate your full range of bagged product

SERIES HDV SPECIFICATIONS

Lengths (Centerline of pulleys)	Standard length is 8'. Optional lengths available to 14'.
Belt	Two 8" wide, 120# smooth PVC belts with mechanical belt fasteners. Belt speed is 40 FPM.
Drive	Right angle gear reducer with roller chain final drive.
Frame	12 gauge formed and welded steel slider bed for maximum bag support.
Power	1/2 hp TEFC three phase C face motor is standard through 10'. 1 hp for 11' through 14' lengths. Other options are available upon request.
Pulleys	6" diameter head and tail pulleys with 1 1/4" diameter shafts and regreasable cast bearings.
Supports	2" x 4" telescoping structural tubing for 13" to 29" top-of-belt heights.

SERIES HDV BELT GUARD



SERIES V/HDV OPTIONS

MANUAL JACK ASSEMBLY -

Dual-screw jacks with common connecting shaft assures level conveying at any height. Provides 12" of adjustment in conveyor height.

ELECTRIC LIFT -

The same common sense features of the manual jack assembly with the addition of a right angle gear reducer and 1/2 hp motor.

CASTERS -

Four swivel casters allow you to use the same conveyor for multiple bagging operations within your plant. Casters allow for easy positioning of your Series V/HDV conveyor.

FRONT AND BACK BAG GUIDES -

Front and back bag guides are available for additional support of bags through your closing system.

CUSTOM SPECIFICATIONS -

Any conveyor width, length or option can be custom configured to handle product within your plant.

